

Archem Process Equipment Ltd.

45-1548 Richmond St., London, ON N6G 4W7 Canada
Tel: (519) 858 0443 • Toll free: 1-877-746-8278 • Fax: (519) 858 0449
email: rricher@execulink.com

What we do...

- We buy, sell and rent used process, packaging and general plant equipment.
- We manufacture double planetary mixers & we refurbish Ross & other brands
- We deal with the chemical, pharmaceutical, food, adhesives & sealants, plastics, metals, ceramics and rubber industries.
- Maximize returns with consignment sales or surplus assets management program
- We offer *appraisal services*, obtain realistic figures for replacement or liquidation.

Buying or selling?...Call now for results!

Toll free: **1-877-746-8278** Local: **(519) 858 0443**
email: rricher@execulink.com

Quality Why Buy Used Equipment?

- Save money - 40%-90% compared to new.
- Save money with new surplus equipment.
- Save the environment. Eliminate tons of new CO₂ emissions by buying existing quality machines.
- Immediate delivery, get it **now** when you need it.
- All the good equipment in your plant is used.
- Get more for your money.

Ross HDM-40 Gal. double planetary mixer, formerly used for granulation in a pharmaceutical plant. New in about 1990.



We are now agents for OLSA, manufacturers of pharmaceutical grade equipment. Products include Vacuum Mixers, Vacuum Dryers, Pharmaceutical Ovens, Water Stills, Clean Steam Generators, Nutsche Filters, Filter Dryers, Processing Vessels & Fermenters.

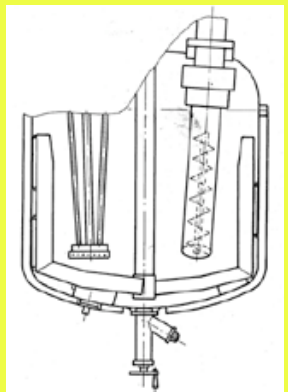

NEW

Archem double planetary mixers. We make our own from 1 quart to 200 gallons.

Just Purchased

- Ross HDM-200
- Myers 80 Gal 3 Shaft, Pharma Gr.
- Jaygo/Saturn Vertical Cone Mixer Pharma Gr.

AGITATORS

New Surplus Lightnin

75C-10, 10 HP, 46" Ø Anchor
74-C-7.5, 7.5 HP, 45" Ø Anchor
(4) 75-C-5, 5HP, 53.8" Ø Anchor
74C-10, 10HP, 34.75" Ø Anchor
74S-30, 30 HP, used drive only

BLENDERS

Littleford Type 5 Ltr.
Littleford FKM 300
Littleford FKM 600
Littleford Type 2000 Ltr., SS, Jkt
V-Blender 2 Qt, SS, Sanitary
P-K V-Blender 10 cu. ft., CS.
Double Cone Blender ~ 4 cuft
Jaygo/Saturn Nauta Type 45
L, SS, vac., pharma. grade
Day, Nauta Type 70 cu. ft., SS,
vac., jckt, choppers, Sanitary

Jaygo/Saturn Nauta Type 45 Ltr Vac from Pharma



CRANES

Hoist Equipment Company:
1/2 ton, electric, suspends from
ceiling, covers an area approx.
10' X 22'. Two units available.

EXTRUDERS

Pilot/Lab Scale unit Available

HEAT EXCHANGERS

New Surplus Graphite

Korobon Impervious Graphite
Plate Heat Exchangers, 4 & 5
square meter units

WANTED
YOUR SURPLUS
LITTLEFORD PLOUGH
SHARE BLENDERS

RIBBON BLENDERS

Ross 5 CU. FT., Sanitary SS
New 52 Cu. Ft., Sanitary SS
New 100 Cu. Ft., Sanitary SS

Ross Double Planetary HDM-40 Gal from Pharma



WANTED

ROSS MIXERS

PD-40 PD-100 PD-200
HDM-10 HDM-40
HDM-100 HDM-200
LDM-2 LDM-1
PVM-100 to 500 & Larger
**Dual Shaft Mixers with
anchor & disperser**

ROSS, MYERS & REYNOLDS MIXERS

Change Can & Paste

Lab Scale

DOUBLE PLANETARY:

Ross LDM-1 Quart
Ross LDM-1 Callon & Press
Ross LDM-2 Gallon
Ross PD-2 Gallon
Ross LDM-4 Callon & Press

MULTI SHAFT MIXERS:

Myers 2QT, Coaxial, Vac/Jack
ROSS PVM-2, Pharma Grade
Myers 5 Gal, SS, Vac/Jacket
Myers 80 Gal, SS, Vac/Jacket

Production Scale

DOUBLE PLANETARY:

Ross HDM-10
Ross PD-10
Jaygo MPVDV-60 Ltr., 15 Gal.
Ross HDM-25
Ross HDM-40 Sanitary unit
Ross HDM-40 Vac & Non-Vac
Ross HDM-100 Vac & Non-Vac
Ross HDM-200 Vac, SS, 2 units
Ross VMC-200 Gal 3-Shaft
Ross HDM-500 & Press

MULTI SHAFT MIXERS:

Myers 5 Gal, SS, Vac/Jacket
Ross PVM-10
Ross PVM-150 Sanitary Unit
Ross FDA-330 Tripple Shaft

Tanks

For Ross 4 Gal Mixers
For Ross 100 Gal Vac Mixers
***We manufacture Double
Planetary Mixers & Tanks***

PACKAGING

PI/Sencorp, 2-3,000 blisters/hr
Metal Squeeze Tube Fillers:
Unipac XP filler, 37 tubes/min,
works with 45, 30 & 15 ml
Arenco, 2 ml, 24 tubes/min.

OLSA Vacuum Mixer-Homogenizer

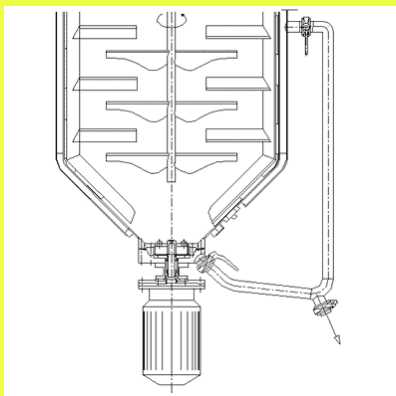

VACUUM PUMPS

Piab Vacuum Pumps, several units available.

RIBBON BLENDERS New Stock & Custom

We stock new sanitary ribbon blenders and we also build to your specifications. Our prices are very good! May we quote?



SCREENING EQUIPMENT

RUSELL FINEX: Model 25070, Three decks, SS contact parts. Lab 20" Screener

DAY NAUTA TYPE 70 ft3, SS sanitary, Vac.



TANKS Steel & Stainless Steel

150 IG CS Mixer, Electric Heat
300 IG CS Mixer, Electric Heat
500 USG SS Vessel
1,500 & 2,000 IG SS, Vacuum, Dual Shaft Mixer
5,000 IG SS Sanitary, 2 units

V-BLENDERS

We build V-Blenders. We stock a few sanitary units and we can build to suit your needs. Our prices are very good!



VESSELS & REACTORS New Surplus Glass Lined

Manufactured by Lampart, Budapest, Hungary
Several units - Call for listings.

VESSELS STAINLESS STEEL

500 gallon, 316LSS, Vacuum, pressure vessel

**ROSS PLANETARY
HDM-200 Gal, SS, Vacuum
2 jacketed mix cans with valves. Just purchased.**



WE MAKE TANKS - PRESSES

Tank & discharge press we made for a Ross 4 gallon double planetary mixer



Response Form

email: rricher@execulink.com or Fax: (519) 858 0449

✓

- Email me updates of available equipment and plant liquidations
- I am looking for equipment (describe below).
- I have equipment for sale (describe below).

Your contact info:

Name: _____

Title: _____

Company: _____

Street: _____ Code: _____

City: _____ Prov/State: _____

Tel: _____ Fax: _____

Email: _____



Send us your
**email
address**
to receive current
offers on equipment &
plant liquidations.

Brand/Model

Description: Size, Features, Year & Price

_____	_____
_____	_____
_____	_____
_____	_____
_____	_____
_____	_____
_____	_____
_____	_____
_____	_____
_____	_____
_____	_____

Every piece of quality equipment in your plant is a used machine. Buy quality - used & save!